



Connecting Direct Touch RS 422 to To Allen Bradley SLC 503/504 RS 232 Port.

Product group: Direct Touch
 Information Type: Communications
 Last revised : 15 Mar, 2001

**Touch Panel
RS 422 terminal**

FA-ISONET

**AB RS232
Port**

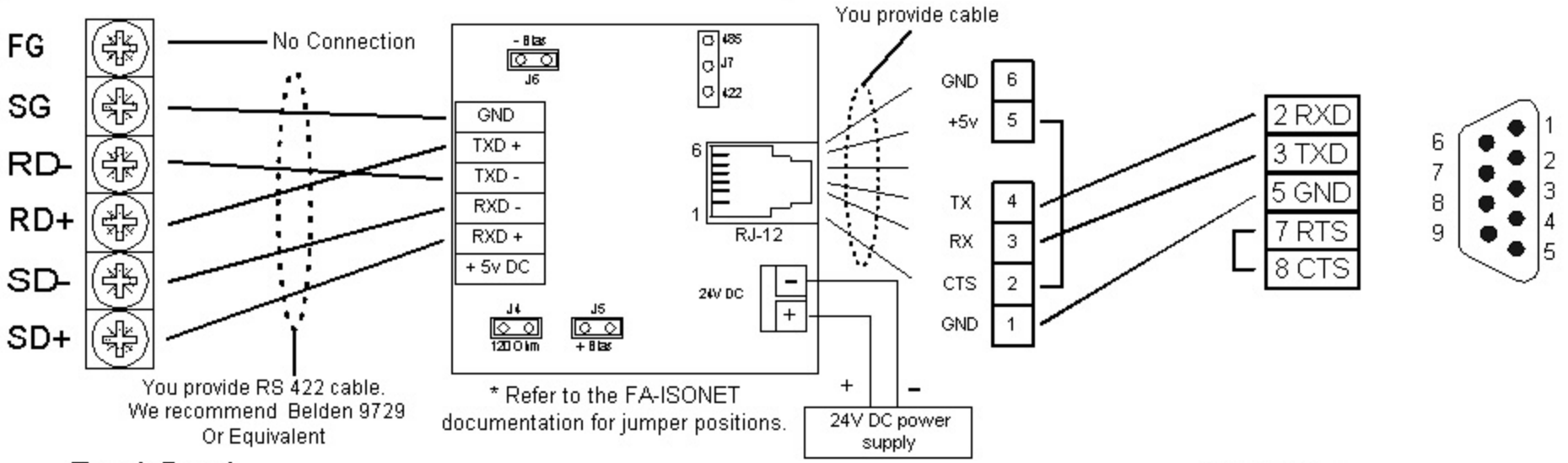

**Touch Panel
RS 422 Configuration**

**AB Chan. 0
RS232 Configuration**

Connected Device	PLC
Communication Rate	9600
Parity	Even
Stop Bit	1
Data Length	8

Note:The Baud rate and Parity must match between the Touch Panel and the PLC.
 Depending on distance it may be necessary to increase the Timeouts and Retries in the Touch Screen. They can be accessed by selecting the **Detail** tab when configuring the comm port on the touch panel.

Driver	DF1 Full Duplex
Baud	9600
Parity	Even
Control Line	No Handshaking
Error Detection	BCC
Embedded Resp.	Enabled
ACK Time	50
NAK Retries	3
ENQ Retries	3