

PROXIMITY SENSOR TERMINOLOGY

Never use this desk reference for installation or operation of equipment. Refer to manual for installation and operation instructions.

The following descriptions refer to the European standard EN 60947-5-2, of Sept. 95.

The specifications given here are intended to be minimum performance values described by the standard.

Alignment

Proximity switches must not be mutually influenced. For this reason, a minimum distance between them (referred to as alignment) must be provided.

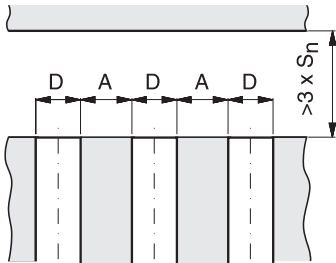

Size D	Embeddable A (mm)	Non-Embeddable A (mm)
Ø3	0	--
M4	0	--
Ø4	0	--
M5	0	--
5X5	0	--
M8	2/3*	8
8X8	2/3*	--
M12	6/10*	12
M18	12/20*	30
M30	30	60

*Extended distance models

Break function (N.C., normally closed)

A break function causes load current to flow only when a target is not detected.

Degree of protection

If not otherwise specified, proximity switches (*when installed in accordance with manufacturer's instructions*) have minimum IP65 protection against dust and water jets.

Differential travel (H)

The differential travel is given as a percentage of the effective operating distance (S_r) and is the maximum difference between the switching distances. The differential is intentionally introduced to guarantee the stability of the output state in case the target is positioned near the switching points.

Distance/target size graph

Indicates the ON switching distance when target material and size changes.

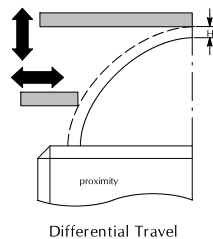

Below are some typical values for different target material of standard dimension:

- Inox steel: $0.6-1 \times S_n$
- Brass: $0.35-0.50 \times S_n$
- Aluminum: $0.35-0.50 \times S_n$
- Copper: $0.25-0.45 \times S_n$

Detection area graph

This is a graph of the parallel displacement needed to switch on (switch off, dashed line) as a function of the target distance. The construction of the curve is obtained by measuring the lateral distance between the sensor axis and the edge of the target necessary to switch on or off at any target distance (see figure below.)

Electrical connections

Keep sensor cables and power cables separated to avoid electrical interference.

The power supply voltage must not exceed the specified limits UB.

If a non-stabilized supply voltage is used for DC sensors, the maximum voltage peak under minimum power consumption conditions and minimum voltage peak under maximum power consumption must not exceed UB limits.

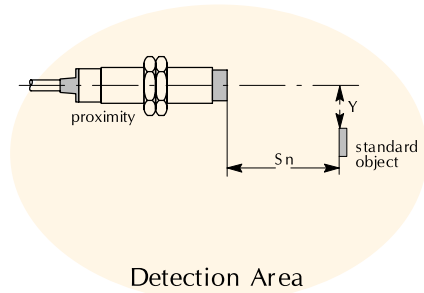

If the power supply of the sensor is also used to switch inductive loads, a suppression device must be provided. A fuse to protect the power supply line is also recommended.

Installation notes

Select a sensor compatible with the operating environment: verify the compatibility between building materials, the presence of chemicals, temperature range, protection degree, vibrations, shocks, EMC, supply voltage available, load type, etc.

Select the sensor by referring to the size and type of material to be detected.

Check the minimum distances between sensor and damping materials or another sensor.

PROXIMITY SENSOR TERMINOLOGY

Installation notes, (cont.)

Check that the number of operations does not exceed the maximum switching frequency. If the phase of the output signal is important, check the turn on and turn off time.

Metallic chips or dust must not accumulate on the sensing face. The distance between the sensor and the object to detect must not exceed the assured operating distance S_a ; the best operating distance is $S_n/2$.

Check the effect of vibrations.

Install the sensor using the installation accessories and do not exceed the maximum tightening torque.

Leakage current

The leakage current is the current which passes through the output transistor when it is blocked (this must be taken into account, especially in the case of parallel connection of several switches).

LED status indicators

Proximity switches may incorporate one or more color indicators. The meaning of the colors are:

- CONTINUOUS GREEN: Power ON
- CONTINUOUS YELLOW: Output ON
- CONTINUOUS RED: Fault
- (on AC models, RED = output ON)

Make function (N.O., normally open)

A make function causes load current to flow only when a target is detected.

Material influence

The nominal sensing distance $S(n)$ is defined using precisely defined measuring conditions (See **Operating Distance**.) Other conditions may result in a reduction of the operating distance. The tables in the next column show the influence different target materials have on the operating distances of the sensors.

Material Influence: Table 1	
Target Material	Operating Distance
Steel Type FE 360	$S(n) \times 1.00$
Brass	$S(n) \times 0.64$
Aluminum	$S(n) \times 0.55$
Copper	$S(n) \times 0.51$
Stainless Steel (V2A)	$S(n) \times 0.85$

Material Influence: Table 2	
Target Material	Operating Distance
Steel Type FE 360	$S(n) \times 1.00$
Brass	$S(n) \times 0.44$
Aluminum	$S(n) \times 0.36$
Copper	$S(n) \times 0.32$
Stainless Steel (V2A)	$S(n) \times 0.69$

Material Influence: Table 3	
Target Material	Operating Distance
Steel Type FE 360	$S(n) \times 1.00$
Brass	$S(n) \times 1.00$
Aluminum	$S(n) \times 1.30$
Copper	$S(n) \times 0.89$
SS (1mm thick)	$S(n) \times 0.57$
SS (2mm thick)	$S(n) \times 0.90$

Mounting

Shielded (embeddable) proximity switches

These proximity switches may be flush mounted regardless of the metal being used. For reliable operation, it is necessary to observe the minimum distances from adjacent metal targets.

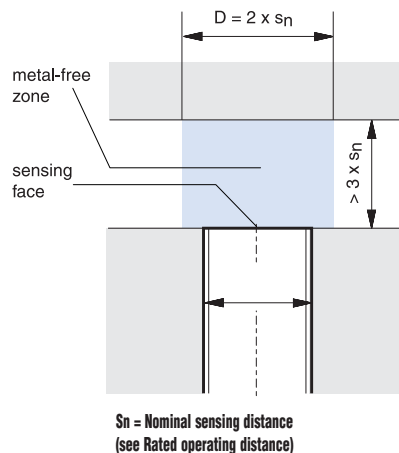

Unshielded (non-embeddable) proximity switches

When mounting non-embeddable mounting proximity switches in conducting materials (metals), it is necessary to observe the minimum distances from adjacent metal targets. Flush mounting in non-conducting materials is permitted.

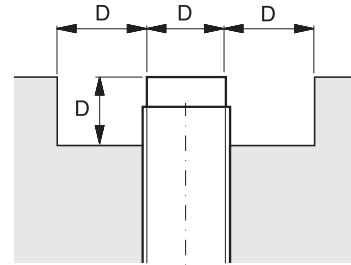

Off-state (leakage) current (Ir)

This is the current that flows through the load circuit of the proximity switch in the OFF state at the maximum supply voltage.

Open collector

The output transistor is not internally connected to a pull-up or pull-down load. It is therefore possible to connect an external load supplied by an external voltage.

Operating distance (sensing range) (S)

The operating distance is the distance at which a standard target approaching the active face of the sensor causes a sensor output state change.

Output type and load connections – 3-wire NPN

There are two power wires and one output wire. The switching element is connected between the output wire and the negative terminal, and the load is connected between the output wire and the positive terminal. In the ON state, the current sinks from the load into the switching element.



PROXIMITY SENSOR TERMINOLOGY

Output type and load connections –3-wire PNP

There are two power wires and one output wire. The switching element is connected between the output wire and the positive terminal, and the load is connected between the output wire and the negative terminal. In the ON state, the current flows from the switching element into the load.

Overvoltage protection

No damage will occur in the presence of surge pulses exceeding UB and energy less than 0.5J.

Polarity reversing protection

No damage will occur to proximity switches if the supply wires are reversed.

Protection against inductive loads

Unless otherwise specified, DC sensors are protected against inductive over-voltage by use of a surge diode or a zener diode.

Unshielded proximity switches

The sensor housing does not cover the side of the sensing head. This type of sensor has a higher sensing range than the shielded type.

Rated insulation voltage (Ui)

Unless specified differently, all of the sensors with a supply voltage of up to 50VAC and 75VDC are tested at 500VAC.

Sensors with a supply voltage up to 250VAC are tested as follows:

- Class 1 (with earth terminal) at 1500VAC
- Class 2 (with double insulation, without earth terminal) at 3000VAC.

Rated operating distance —(nominal sensing distance) (Sn)

This distance does not take into account manufacturing tolerances ($\pm 10\%$) or variations due to external conditions, such as voltages and temperatures not falling within the rated values.

Repeat accuracy (R)

The repeat accuracy of the effective operating distance (S_r) is measured over an eight hour period at an ambient temperature of 73°F ($\pm 9^\circ$) [23°C ($\pm 5^\circ$)] at a specified humidity and with a specified supply voltage. The difference between the measurements shall not exceed the specified value, or if not specified, 10% of S_r .

Ripple

This is given as a percentage of the mean supply voltage. It is the maximum peak-to-peak value of the admitted ripple voltage. A ripple voltage of $<10\%$ U_e is desirable.

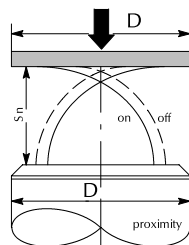

Rated Operating Distance

Shocks

In accordance with IEC 68-2-27

- Pulse shape: half-sine
- Peak acceleration: 30g
- Pulse duration: 11ms

Shielded proximity switches

A metal housing surrounds the coil, and only the front of the active face is sensitive. The device allows flush installation on metal plates without any performance change. Refer to Alignment when installing shielded sensors side-by-side.

Short-circuit protection

All DC sensors have integrated short-circuit protection. AC sensors should be protected externally by such devices as fuses.

Standard target

A standard target is square, 1mm thick, and made from type FE360 carbon steel. The length of the side of the square is equal to the diameter of the sensor's active surface, or three times the rated operating distance (S_n), whichever is greater.

Switching frequency (f)

Switching frequency is the maximum output switching frequency performed by the output circuit when standard targets cross the sensing field at a distance of $S_n/2$. The targets are spaced $2d$.

- For DC sensors, the minimum output pulse width must not fall below 50 μ S.
- For AC sensors, the minimum output pulse must not fall below half a sine period (ie. for 60 Hz, $1/60 \div 2 = 8.33\text{ms}$.)

Temperature range

Unless otherwise specified, the minimum temperature range is -13 to $+158^\circ\text{F}$ (-25 to $+70^\circ\text{C}$).

Turn-on time

Turn-on time is the elapsed time from when the target enters the sensing range until the output switches.

Turn-off time

Turn-off time is the elapsed time from when the target is removed until the output switches.

PROXIMITY SENSOR TERMINOLOGY

Voltage drop (Ud)

This is the voltage measured across the active output of the proximity switch when the rated operational current (I_e) flows in the load at the rated supply voltage and the temperature is at 73°F ($\pm 9^\circ$) [(23°C ($\pm 5^\circ$)). Unless specified differently, the following values are guaranteed:

- Two-wire DC models <8VDC
- Three-wire DC models <3.5VDC
- Two-wire AC models <10VDC

Vibration

In accordance with IEC 68-2-6

Frequency range: 10-55Hz

Amplitude: 1mm

Sweep cycle duration: 5min.

Duration of endurance at 55Hz: 30 min. in each of the three axis directions

4-wire NPN or PNP (programmable output state)

There are two power wires, one N.O./N.C. selection input wire and one output wire. The output state is programmable by connecting the input wire to one of the power supply lines.

4-wire NPN or PNP (complementary outputs)

There are two power wires, one normally open output wire and one normally closed output wire.

4-wire NPN and PNP

There are two power wires, and the output type is wiring programmable. An NPN output is available by connecting the PNP terminal to the negative power supply line. A PNP output is available by connecting the NPN terminal to the positive power supply line.

Time delay before availability (tv)

The time delay before availability is the time between the switching on of the supply voltage and the instant at which the sensor becomes ready to operate correctly.

During the reset the output circuit is in OFF-state; false signal may be present but the duration shall not exceed 2 ms. If not specified otherwise, the reset duration doesn't exceed 300ms.

FIELD DEVICE EXAMPLES - 3 WIRE CONNECTIONS

NPN (Sinking)
Field Device Example

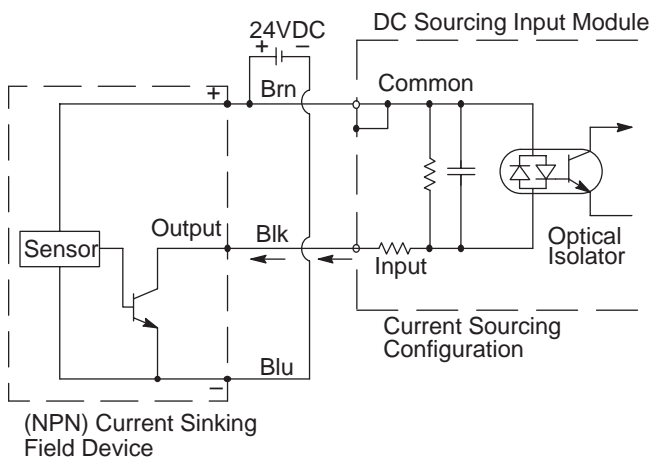

PNP (Sourcing)
Field Device Example

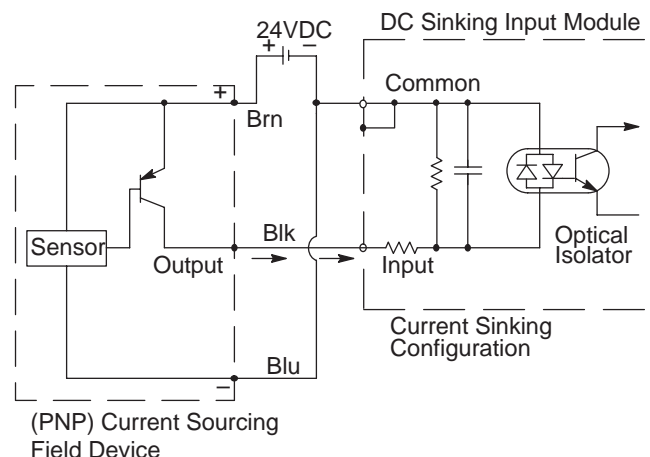

FREQUENTLY ASKED QUESTIONS

How do inductive proximity switches work?

Inductive proximity switches are used to detect the presence of metallic objects without actually contacting the object. Their high-speed switching and small size make them indispensable in automation applications.

Inductive proximity switches consist of a coil driven by an oscillator. The oscillator creates an electromagnetic field which appears at the active face of the switch. If a metal target enters this area, the electromagnetic field is reduced and the switch turns on or off.

Some typical inductive sensor applications are: counting metallic objects, monitoring the position of elements in a machine, sensing the presence of metallic parts like screws, etc., and measuring the rotational speed of axial detecting cams.

What is the difference between inductive and capacitive sensors?

The primary difference is sensing material. Inductive sensors only detect metallic objects while capacitive sensors will detect materials such as wood, paper, liquids, cardboard, etc.

How do I know what size proximity sensor I need?

It depends on two factors: mounting space and sensing distance. Each application has a specific space available for the sensor and each application has a requirement for how close the sensor can be mounted to the sensed object.

What is the difference between shielded and unshielded?

With a shielded proximity sensor, the face of the sensor may be mounted flush with metal whereas an unshielded sensor may NOT be mounted flush with metal (otherwise the sensor will always be ON). In many applications, flush mounting is a requirement. Also, unshielded proximity sensors allow for greater sensing distances.

What output do I need? NPN or PNP?

This is determined by the device you are connecting the sensor to. Most DirectLOGIC PLC modules (except 305 series) allow NPN or PNP sensors to be connected. This is determined by how the sensor is wired to the PLC.

How do I choose between normally open (N.O.) and normally closed (N.C.)?

N.O. sensors do not pass power to the PLC until an object is detected. N.C. sensors always pass power to the PLC until an object is detected. The majority of Centsable sensors are N.O.; however, some sensors offer the option of N.C., such as PKW, PMW and CT1 series.

When do I want quick disconnects (Q/D) versus embedded cable output?

There is a slight cost increase to purchase a sensor and a Q/D cable compared to only purchasing a sensor with a pre-attached cable. However, the Q/D output allows easy replacement of a failed sensor. This is important in minimizing machine or operation downtime.

What is the difference between 2-wire, 3-wire, and 4-wire sensors?

2-wire sensors: allows either NPN or PNP outputs (don't have to select).

3-wire sensors: standard sensors. When ordering, you must choose between NPN and PNP output.

4-wire sensors: Allow either N.O. or N.C. outputs (don't have to select). Must still select NPN or PNP output.

Do Centsable sensors operate on AC or DC voltage?

The majority of Centsable sensors operate on 10-30 VDC. However, we do offer the VT1, VK1, and VM1 series that operate on 20-253VAC.

Can my sensor be installed in a washdown area?

Yes. All Centsable proximity sensors carry an IP67 or IP68 enclosure rating. This rating allows temporary submersion of the sensor into water.

What does switching frequency mean to my application?

This is how fast your sensor can sense an object, reset, and sense another object. For example, if a sensor has a switching frequency of 100Hz or 100 cycles per second, the sensor can sense a maximum of 100 objects per second. This is very critical in many applications such as gear rotation measurement.

Can the sensor be put into a vibrating environment?

Yes. Frequency range of 10-55 Hz, maximum amplitude of 1mm. Duration in any axis a maximum of 30 minutes.

What is the temperature range of the sensors?

Most sensors operate between -25° and 70° F. However, check the specifications for exact ranges.

If I wire my proximity sensor wrong, will it damage it?

Possibly. All sensors contain polarity reversal, short-circuit and transient noise protection. However, the transient protection is only effective under 30VDC.